



4/94 Haig Street Gordon Park QLD

2  1  1 

Why fight for a rental, attend countless showings and submit endless applications when this comfortable and affordable home could be all yours? Perfectly suited to eager first-time buyers and downsizers alike, this Gordon Park property will impress from the moment you arrive.

The enviable ground-floor location ensures ease of access and ample outdoor space while inside, you're treated to two good-size bedrooms and a central bathroom. The open-plan kitchen, dining and living area will feel bright and generous with glass sliding doors that flow freely to the fenced and low-maintenance courtyard.

You will spend endless hours this summer enjoying this outdoor area whether you're entertaining loved ones or simply starting the day with your morning coffee. Low-maintenance gardens mean you can truly kick back

Price : \$ 420,000
Building Size : 129 sqm
View : <https://www.aumr.com.au/1P4786>



Jay Wu
0402 686 929

4/94 Haig Street, Gordon Park

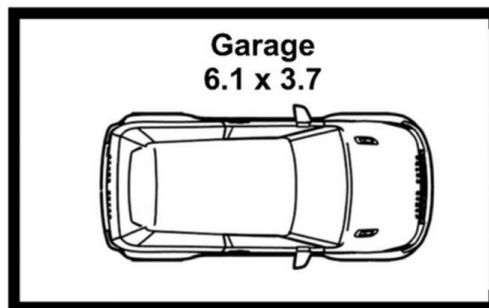

Internal:- 78sqm
External:- 28.4sqm
Garage:- 22.6sqm
Total:- 129sqm

Floor plans are for illustration purposes only.
Measurements are in metres and are approximate.